

717H

SINOMACH

SINOMACH

SINOMACH-HI INTERNATIONAL EQUIPMENT CO.,LTD.

额定功率(Rated Power):132kW@2200rpm

操作重量(Operating Weight):14000Kg (Standard)



- Equipped with Dong Feng Cummins engine.
- Single-handle electro-hydraulic controlled power shift T/M,6 forward & 3 reverse shifts makes operation easy and convenient.
- Optimum axle load allocation provides excellent stability while grading rough and rocky area.
- Box-Type frame and advanced T/M enable it to complete heavy-duty work.
- A wide working range is accomplished through flexible moldboard suspension system and articulated frame.



Wheel Loader



Motor Grader



Excavator



Backhoe Loader



Vibratory Roller



Truck Crane



Bulldozer



Paver



Skid Steer



SINOMACH-HI INTERNATIONAL EQUIPMENT COMPANY LIMITED

Add:No.898,West Huanghe Road, Changzhou, Jiangsu,
P.R.of China

P.C:213136

Tel:86-519-86781288 86752400

Fax:86-519-86781387

Http://www.sinomach-hi.com

E-mail:sales@changlin.com.cn service@changlin.com.cn



国机重工集团国际装备有限公司
SINOMACH-HI INTERNATIONAL EQUIPMENT CO.,LTD.



发动机(Engine)

型号.....康明斯6BTA5.9
Model.....Cummins 6BTA5.9
型式.....直喷、涡轮增压、水冷
Type.....Direct injection、turbocharged、water cooling
额定功率Rated Power..... 132kW@2200rpm
最大扭矩Max. torque.....750N.m@1300rpm



变速系统 (Transmission System)

ZF技术的电液控制动力换挡变速箱，单手柄操作，中位锁定。
Electro-hydraulic controlled power shift transmission adopted ZF technology, single handle operation, lock in the neutral.
行驶速度(km/h) Traveling speed (at rated engine rpm)

Gearshift	Forward speed	Reverse speed
1 st	6.5	6.5
2 nd	11.4	14.6
3 rd	14.6	30
4 th	24.8	
5 th	30	
6 th	49.2	



液压系统 (Hydraulic System)

系统压力System pressure.....17.5mpa
发动机额定转速时的流量.....99L/min
Flow rate at engine rated speed.....99L/min



转向 (Steering System)

前轮的最大转向角.....左右各 49°
Max. turning range.....left or right 49°
车架转向角.....左右各 26°
Frame articulation.....left or right 26°
最小转弯半径.....7300mm
Min. turning radius.....7300mm
系统压力 System pressure.....16mpa
发动机额定转速时的流量..... 55L/min
Flow rate at engine rated speed..... 55L/min



车桥 (Axles)

前桥.....中央离地间隙 610mm，摆角为±16°
Front axle.....Ground clearance 610mm and oscillation angle (total)±16°
前轮倾斜角 wheel lean angle.....right or left 17°
后桥：全浮式后桥，带 NO-SPIN 差速器
Rear axle: full-floating rear axle with NO-SPIN differential



终传动 (Tandem Drive)

平衡箱摆角 (Tandem oscillation).....13° forward and reverse
终传动.....螺旋锥齿轮，单级减速。
Final driving.....Spiral bevel gear, single stage reduction
串联传动.....采用双排滚子链
Tandem drive.....Double row roller-chains



制动 (Brakes)

行车制动.....全液压制动，鼓式制动器
Service brake.....Hydraulic brake system, drum brake
停车制动.....软轴操纵作用内涨鼓式制动器。
Parking brake.....Flexible shaft control actuated inner-expanding drum brake



铲刀 (Moldboard)

铲刀尺寸 Dimensions.....3658mm×545mm×16mm



刀板变动范围 (Blade Range)

铲刀移动距离(Moldboard side shift)
Right.....815mm
Left.....815mm
Max. shoulder reach outside rear tires(frame straight)
Right.....2000mm
Left.....2000mm
Max. lift above ground.....450mm
Max. grading depth.....535mm
Max. blade angle, right or left.....90°
Blade tip angle.....29°~77°



轮胎 (Tyre)

轮胎规格 Tyre size.....17.5-25-12PR L-3



驾驶室 (Cabin)

Vibration-absorbed humanistic cabin with adjustable steering wheel and seat, and streamline dashboard provide low noise, air conditioning, comfortable operation and wide eyeshot.



油量 (Refill Capacity)

燃油箱 Fuel tank.....330L
变速箱 Transmission.....28L
曲轴箱 Crank case..... 17L
后桥 Rear axle.....18L
平衡箱(单边) Tandem housing(each).....45L
液压系统 Hydraulic system.....65L
涡轮箱 Circle reverse housing.....3.8L

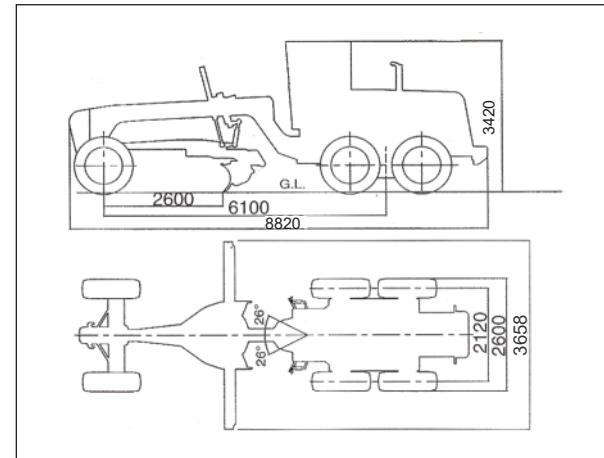

Comfortable Cabin



■ Full-closed cabin with the visibility up to 47%.

Best Matched Power Train

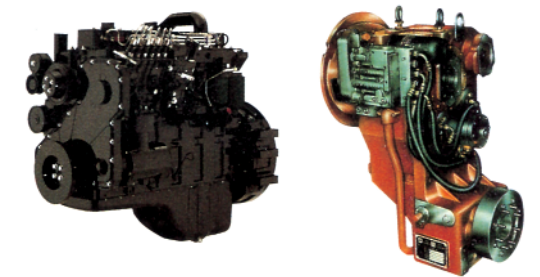

■ Equipped with Cummins engine that features strong power and low oil consumption.
■ ZF technology transmission with single handle that features perfect performance and easy operation.

Imported Multil-way Valve & Booster

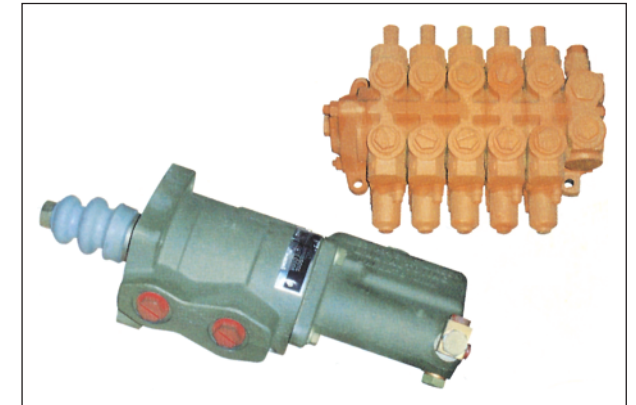

■ Adopted imported components in crucial places greatly enhance reliability.

Optional Attachment

1. 空调Air conditioner
2. 轮胎Tyre size: 13.00-24-12PR G-2
3. 自动找平仪Automatic leveling device
4. 防滚翻ROPS Frame
5. 推土板Front Blade
6. 前松Scarifier
7. 后松Ripper

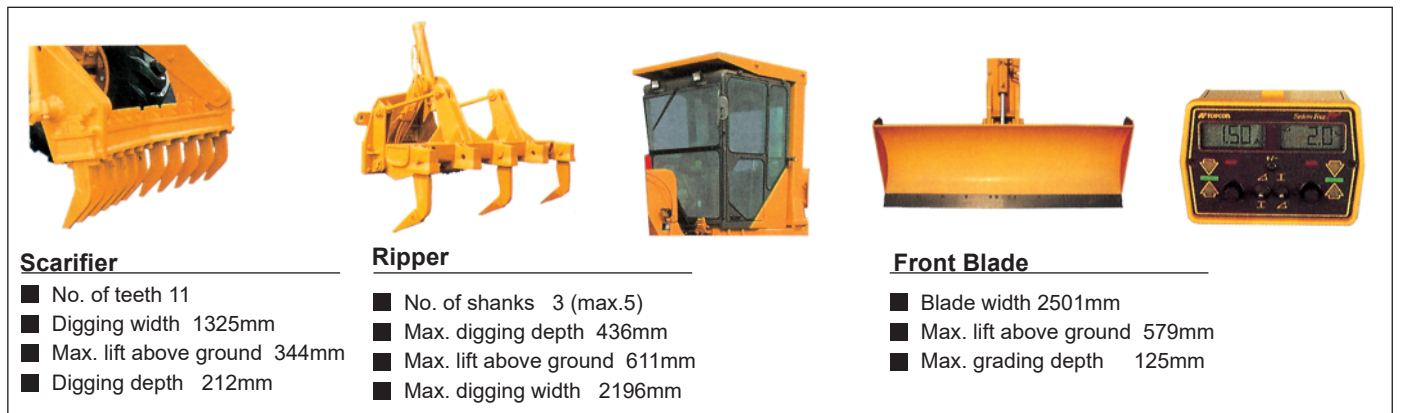

Scarifier

- No. of teeth 11
- Digging width 1325mm
- Max. lift above ground 344mm
- Digging depth 212mm

Ripper

- No. of shanks 3 (max.5)
- Max. digging depth 436mm
- Max. lift above ground 611mm
- Max. digging width 2196mm

Front Blade

- Blade width 2501mm
- Max. lift above ground 579mm
- Max. grading depth 125mm